

The selection is detailed on page 8



LW-PM

Flush Diaphragm Pressure Transmitter

Working principle

The working medium pressure is transmitted through the standard process connector and then affects the internal pressure sensor element. Internal electronics convert raw transmitter signals into filtered, amplified, temperature compensated and standardized signals such as 4... 20mA signal, etc. The output signal is transmitted to the next unit for signal processing via standardized connectors or cables.

Product description

This series of products is one of the most ideal choices for applications that require high installation space. The maximum pressure range is 100 MPa. The unique design of the connection of the proprietary stainless steel film sensor to the pressure joint ensures a very high level of measurement performance.

Can be used to measure dynamic pressure or pressure pulses. It can provide 0.5% accuracy, and its stability is also excellent. Unlike other micro pressure transmitters, the flat-panel diaphragm process connection is particularly suitable for measuring viscous, particulate or easily crystallized media.

Product application

Machine building
Liquids are especially suitable for measuring viscous liquids
Gas measurement
General industrial application

Functional characteristics

Measuring range: 0... 1.6MPa to 0... 100 MPa
Current and voltage output signals
Protection level: IP65 or IP67
The shell and the liquid part are made of stainless steel negative pressure protection



Working principle diagram

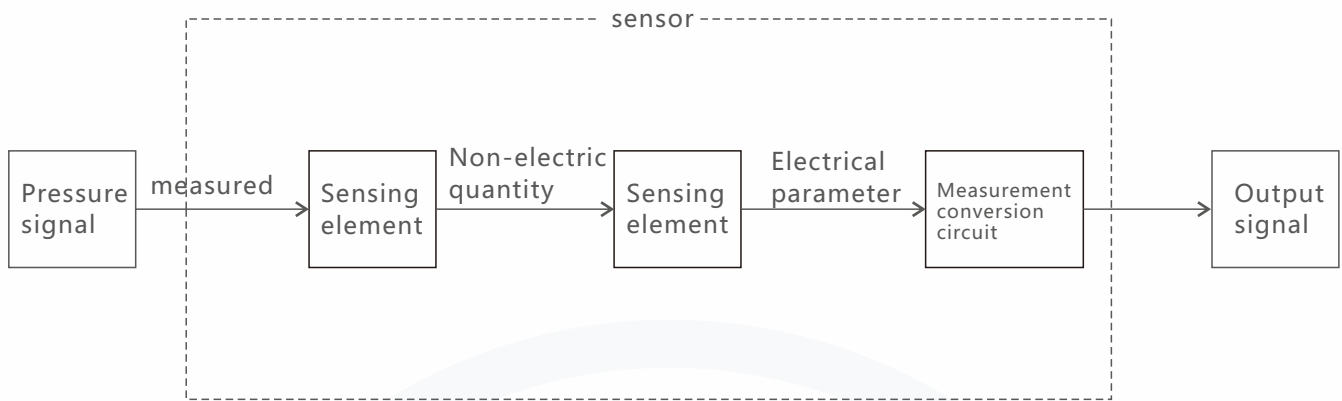

Technical parameter

Range range	See range table
Precision class	1.0%
	0.5%
Pressure limit	Not more than 1500bar
Allowable temperature	
▪ Medium temperature	-10...125°C
▪ Ambient temperature	-40...85°C
▪ Storage temperature	-40...100°C
Process connection	G1/2
Output signal	4-20mA [Two-wire system]
Diaphragm seal ring	FPM/FKM
material	
▪ shell	304SS
▪ Pressure connection	304SS
Power supply	DC 8...32V
Current input	4...20mA < 25mA
Electronic protection	Short-circuit prevention
Degree of protection of electronic connections	The connector matches the junction box ISO 4400 (DIN 43650-A) , IP 65
load	$R_{max} = [(U_B - U_{Bmin}) / 0.02A] \Omega$
Dynamic response characteristics (response time)	
▪ Two-wire system	$\leq 10ms$
▪ Three-wire system	$\leq 3ms$
Temperature effect	When the temperature of the measuring system fluctuates around the reference temperature (+20 °C), the maximum change is $\pm 0.75\% / 10K$ of the range

Technical parameter

Relative pressure								
MPa	Measuring range	0 ... 0.01	0 ... 0.016	0 ... 0.025	0 ... 0.04	0 ... 0.06	0 ... 0.1	0 ... 0.16
	Upper overvoltage limit	0.1	0.15	0.2	0.2	0.4	0.5	1
	Measuring range	0 ... 0.25	0 ... 0.4	0 ... 0.6	0 ... 1	0 ... 1.6	0 ... 2.5	0 ... 4
	Upper overvoltage limit	1	1.7	3.5	3.5	8	5	8
	Measuring range	0 ... 6	0 ... 10	0 ... 16	0 ... 25	0 ... 40	0 ... 60	0 ... 100
	Upper overvoltage limit	12	20	32	50	80	120	150
psi	Measuring range	0 ... 5	0 ... 10	0 ... 15	0 ... 20	0 ... 25	0 ... 30	0 ... 50
	Upper overvoltage limit	29	29	72.5	145	145	145	240
	Measuring range	0 ... 60	0 ... 100	0 ... 150	0 ... 160	0 ... 170	0 ... 200	0 ... 250
	Upper overvoltage limit	240	500	500	1,160	1,160	1,160	1,160
	Measuring range	0 ... 300	0 ... 400	0 ... 500	0 ... 600	0 ... 750	0 ... 800	0 ... 1,000
	Upper overvoltage limit	1,160	1,160	1,160	1,160	1,740	1,740	1,740
	Measuring range	0 ... 1,500	0 ... 2,000	0 ... 2,000	0 ... 3,000	0 ... 4,000	0 ... 5,000	0 ... 6,000
	Upper overvoltage limit	2,900	4,600	4,600	7,200	7,200	11,600	11,600
Absolute pressure								
MPa	Measuring range	0 ... 0.025	0 ... 0.04	0 ... 0.06	0 ... 0.1	0 ... 0.16	0 ... 0.25	0 ... 0.4
	Upper overvoltage limit	2	2	4	5	10	10	17
	Measuring range	0 ... 0.6	0 ... 1	0 ... 1.6	-	-	-	-
	Upper overvoltage limit	35	35	80	-	-	-	-
psi	Measuring range	0 ... 15	0 ... 25	0 ... 50	0 ... 100	0 ... 250	-	-
	Upper overvoltage limit	72.5	145	240	500	1,160	-	-
Vacuum and +/- measuring range								
MPa	Measuring range	-0.06 ... 0	-0.04 ... 0	-0.205 ... 0	-0.016 ... 0	-0.01 ... 0	-0.01 ... 0	-0.01 ... 0
	Upper overvoltage limit	4	2	2	1.5	1	1	1
	Measuring range	-0.1 ... 0	-0.1 ... +0.06	-0.1 ... +0.15	-0.1 ... +0.3	-0.1 ... +0.5	-0.1 ... +0.5	-0.1 ... +0.5
	Upper overvoltage limit	5	10	10	17	35	35	35
	Measuring range	-0.1 ... +0.9	-0.1 ... +1.5	-0.1 ... +2.4	-	-	-	-
	Upper overvoltage limit	35	80	50	-	-	-	-
psi	Measuring range	-15 inHg ... 0	-30 inHg ... 30	-30 inHg ... +60	-30 inHg ... +100	-30 inHg ... +160	-30 inHg ... +160	-30 inHg ... +160
	Upper overvoltage limit	72.5	240	240	500	1,160	1,160	1,160
	Measuring range	-30 inHg ... +200	-30 inHg ... +300	-	-	-	-	-
	Upper overvoltage limit	500	1,160	-	-	-	-	-

The above measuring range can also be converted to mbar, MPa and other units.

Working condition

Electrical connection	Class of protection
Hersman joint DIN 175301-803 A IP 65	IP65
Aviation plug M12 x 1 (4 pins) IP 67	IP67
Standard cable straight out IP67 IP67	IP67
Optional cable direct outlet IP68	IP68 ¹⁾

1) Zero point and measuring range are not adjustable

Vibration resistance	
▪ Process connection without cooling element	20 g (IEC 60068-2-6, In resonance)
▪ Process connection with cooling element	10 g (IEC 60068-2-6, In resonance)
Impact resistance	
▪ Process connection without cooling element	1,000 g (IEC 60068-2-27, Mechanical impact)
▪ Process connection with cooling element	400 g (IEC 60068-2-27, Mechanical impact)

Process connection without cooling element		Process connection with cooling element	
Medium temperature range		Medium temperature range	-20 ...+150 °C (-4 ...+302 °F)
▪ Standard	-30 ...+100 °C (-22 ...+212 °F)	Ambient temperature range	-20 ...+80 °C (-4 ...+176 °F)
▪ selectable	-30 ...+125 °C (-22 ...+257 °F)	Storage temperature range	-40 ...+100 °C (-40 ...+212 °F)
Ambient temperature range	-20 ...+80 °C (-4 ...+176 °F)		
Storage temperature range	-40 ...+100 °C (-40 ...+212 °F)		

Electrical connection

Short-circuit resistance	S+ vs. U-
Polarity reverse protection	U+ vs. U-
Overvoltage protection	DC 36 V
Insulation voltage	Dc voltage of 500 V according to NEC Level 02 voltage standard (up to 100 VA for low voltage and low current even under fault conditions)

Connection diagram

DIN 175301-803 A Hersman joint			
		Two-wire system	Three-wire system
	U+	1	1
U-	2	2	2
S+	-	-	3

Wire section Max. 1.5 mm²(AWG 16)
Cable diameter 6... 8 mm (0.24... 0.31 ")

Aviation Plug M12 x 1 (4 pins)			
		Two-wire system	Three-wire system
	U+	1	1
U-	2	2	2
S+	-	-	3

The cable runs straight out			
		Two-wire system	Three-wire system
	U _B	brown	brown
0V	green	aluminium	white
S+	-	white	gray
shield	gray	gray	gray

Wire section 6 x 0.5 mm² (AWG 20)
Cable Diameter 6.8 mm (0.27")
Cable length 1.5 m, 3 m, 5 m, 10 m, 15 m (4.9 ft, 9.8 ft, 16.4 ft, 32.8 ft, 49.2 ft)

Additional connectors are available upon request.



Size mm

Threaded connections with flush diaphragms

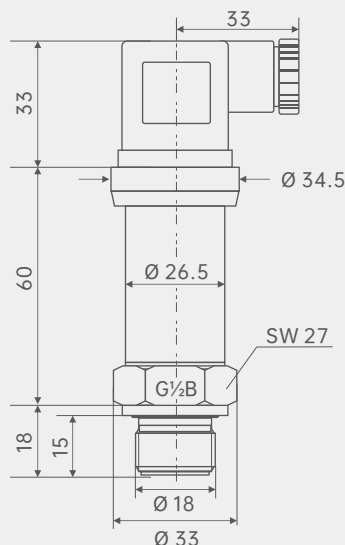
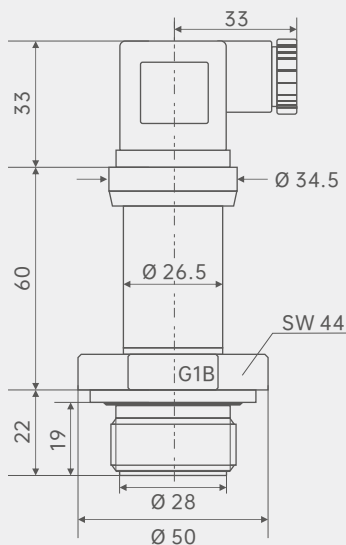

Clamp connection ISO2852

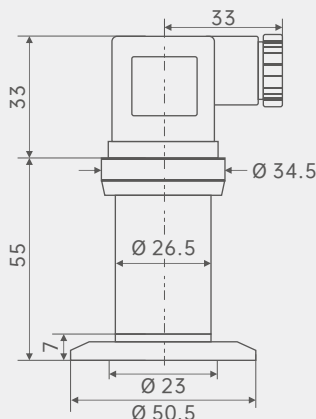

Chuck DIN11851

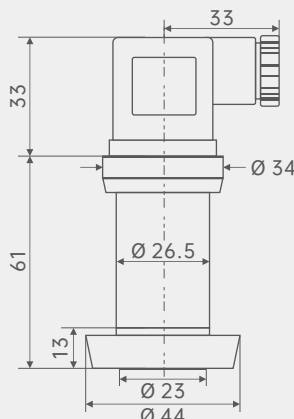

Shell

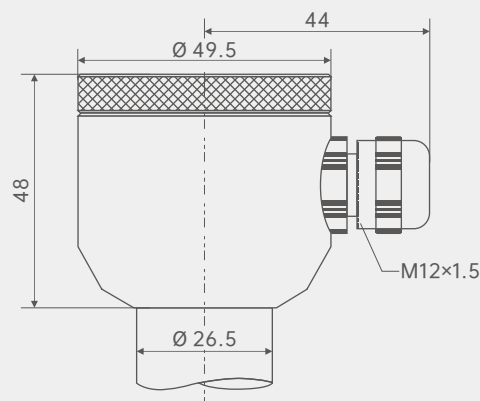

Product shape						
Measurement principle	Varistor stainless steel measuring unit					
Measurement accuracy (IEC60770)	0.35%FSO (< 0.4bar 0.5%FSO > 40bar 0.5%FSO)	0.35%FSO (< 0.4bar 0.5%FSO > 40bar 0.5%FSO)	0.35%FSO (< 0.4bar 0.5%FSO)	0.35% (< 0.4bar0.5%FSO)	0.1% the FSO	0.1% the FSO
Measuring material	Stainless steel 316L/FKM		Stainless steel 316L		Stainless steel 316L/FKM	
Connection specification	G1/2DIN 3852-E Flush diaphragm	G1B DIN 3852-E Flush diaphragm	clamp1" ISO 2852	Conical fitting DIN 11851 DN 25 (aseptum)	G1/2B EN 837	G1/2B DIN 3852 (With flushing diaphragm)
Supply voltage	DC 8-32V	DC 8-32V	DC 8-32V	DC 8-32V	DC 12-36V	DC 12-36V
Output signal	4-20mA	4-20mA	4-20mA	4-20mA	4-20mA	4-20mA
Wire system	Two-wire system	Two-wire system	Two-wire system	Two-wire system	Two-wire system	Two-wire system
Electrical connection	Connectors and junction boxes as per ISO4400 (DIN43650-A)					

Wiring diagram

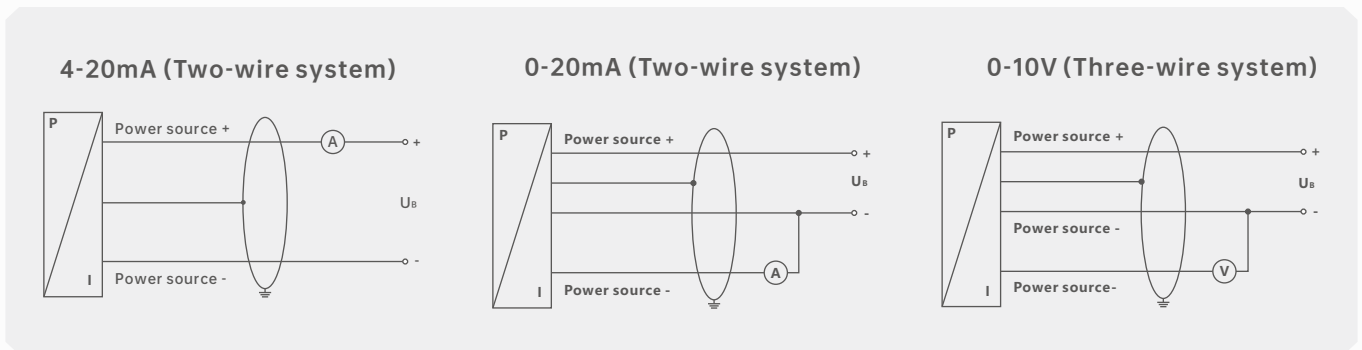

Process connection

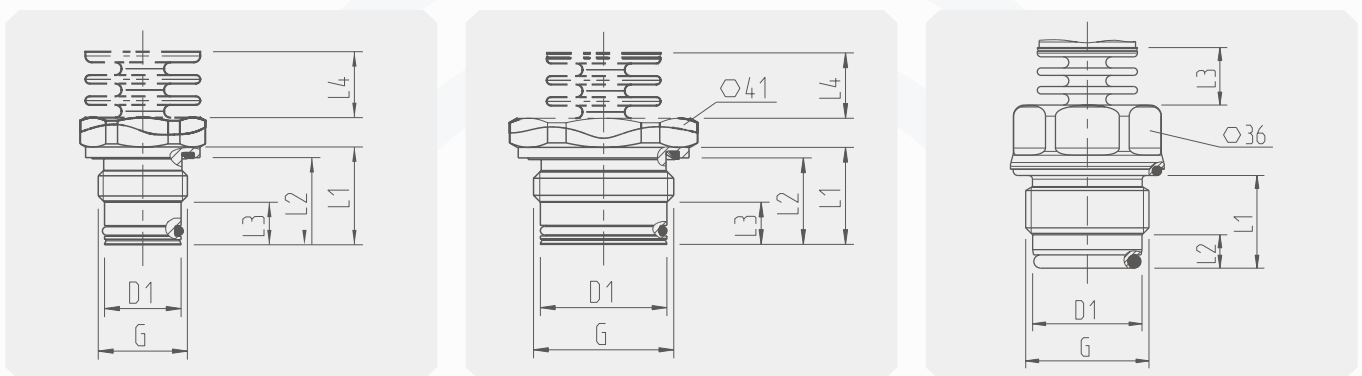

G	D1	L1	L2	L3	L4
G1/2B	18	23	20.5	10	15.5
	(0.71)	(0.91)	(0.81)	(0.4)	(0.61)

G	D1	L1	L2	L3	L4
G1/2B	30	23	20.5	10	15.5
	(1.19)	(0.91)	(0.81)	(0.4)	(0.61)

G	D1	L1	L2	L3
G1/2B (Hygienic type)	29.5	25	9	15.5
	(1.17)	(0.99)	(0.36)	(0.61)

Process connections for use at optional media temperatures (see electrical connection diagram)		
Optional version	Available measurement range	
Flat diaphragmatic type G1/2B	0 ...0.25 to 0 ...60 MPa	0...50 to 0 ...6,000 psi
Flat diaphragmatic type G1B	0 ...0.01 to 0 ...0.16 MPa	0 ...15 psi
Sanitary G1B (meets 3-A sanitary standard)	0 ...0.01 to 0 ...2.5 MPa	0 ...15 to 0 ...300 psi (Separately available)

Sealing element

Process connection	Maximum medium temperature	Sealing materials and maximum pressure limits		
		Standard	Option 1	Option 2
No cooling element	≤ 100 °C (212 °F)	NBR ≤ 60 MPa(8,700 psi)	NBR ≤ 60 MPa(8,700 psi)	EPDM ≤ 20 MPa(2,900 psi)
	≤ 125 °C (257 °F)	NBR ≤ 60 MPa(8,700 psi)	NBR ≤ 40 MPa(5,800 psi)	EPDM ≤ 20 MPa(2,900 psi)
Tape cooling element	≤ 150 °C (302 °F)	FKM/FPM ≤ 30 MPa(4,350 psi)	FKM/FPM ≤ 20 MPa(2,900 psi)	-
Hygienic type	≤ 150 °C (302 °F)	EPDM ≤ 20 MPa(2,900 psi)	-	-

Range table

Negative pressure	code	MPa	code	Bar	code	kPa	code	kg/cm ²	code	Psi/-inHg
	MV001	-0.1/0	BV001	-1/0	KV001	-100/0	GV001	-1/0	RV030	-30"/0 Hg
Positive and negative pressure	code	MPa	code	Bar	code	kPa	code	kg/cm ²	code	Psi/-inHg
	MC006	-0.1/0.06	BC006	-1/0.6	KC006	-100/60	GC006	-1/0.6	PC015	-30"/0/15
	MC015	-0.1/0.15	BC015	-1/1.5	KC015	-100/150	GC015	-1/1.5	PC030	-30"/0/30
	MC030	-0.1/0.3	BC030	-1/3	KC030	-100/300	GC030	-1/3	PC060	-30"/0/60
	MC050	-0.1/0.5	BC050	-1/5	KC050	-100/500	GC050	-1/5	PC100	-30"/0/100
	MC090	-0.1/0.9	BC090	-1/9	KC090	-100/900	GC090	-1/9	PC160	-30"/0/160
	MC150	-0.1/1.5	BC150	-1/15	KC150	-100/1500	GC150	-1/15	PC200	-30"/0/200
MC240	-0.1/2.4	BC240	-1/24	KC240	-100/2400	GC240	-1/24	PC300	-30"/0/300	
Positive pressure	code	MPa	code	Bar	code	kPa	code	kg/cm ²	code	Psi
	MP001	0/0.1	BP001	0/1	KP001	0/100	GP001	0/1	PP1E5	0/15
	MP1E6	0/0.16	BP1E6	0/1.6	KP1E6	0/160	GP1E6	0/1.6	PP003	0/30
	MP2E5	0/0.25	BP2E5	0/2.5	KP2E5	0/250	GP2E5	0/2.5	PP006	0/60
	MP004	0/0.4	BP004	0/4	KP004	0/400	GP004	0/4	PP010	0/100
	MP006	0/0.6	BP006	0/6	KP006	0/600	GP006	0/6	PP016	0/160
	MP010	0/1	BP010	0/10	KP010	0/1000	GP010	0/10	PP020	0/200
	MP016	0/1.6	BP016	0/16	KP016	0/1600	GP016	0/16	PP030	0/300
	MP025	0/2.5	BP025	0/25	KP025	0/2500	GP025	0/25	PP040	0/400
	MP040	0/4	BP040	0/40	KP040	0/4000	GP040	0/40	PP060	0/600
	MP060	0/6	BP060	0/60	KP060	0/6000	GP060	0/60	PP100	0/1000
	MP100	0/10	BP100	0/100	KP100	0/10000	GP100	0/100	PP150	0/1500
	MP160	0/16	BP160	0/160	KP160	0/16000	GP160	0/160	PP200	0/2000
	MP250	0/25	BP250	0/250	KP250	0/25000	GP250	0/250	PP300	0/3000
	MP400	0/40	BP400	0/400	KP400	0/40000	GP400	0/400	PP400	0/4000
MP600	0/60	BP600	0/600	KP600	0/60000	GP600	0/600	PP600	0/6000	
MP1000	0/100	BP1000	0/1000	KP1000	0/100000	GP1000	0/1000	PP1000	0/10000	

LW-PM-Selection composition

Selection example **LW-PM**

1	2	3	4	5	6	7	8	9	10
MP001	A	B	G	O	Z	L	B	E	G

1.Measuring range	R()	See range table (page 7)
2.Output signal	A	4-20mA
3.Power supply	B	DC 8...32V
4.Temperature range	G	0...+80°C
	H	-30...+100°C
5.Precision class	N	0.25%
	O	0.5%
6.Process connection	U	1/2NPT
	V	1/4NPT
	W	M14*1.5
	X	M20*1.5
	Y	M27*2
	Z	G1/2B
	S	G1/4B
	T()	Other connection specifications
7.Seal material	L	fluororubber
	M	Red copper
	T()	Other materials
8.Electrical connection	A	M12*1 (Round joint)
	B	Hersman joint
	C	Head outlet
9.Display type	E	There is no
	F	LED digital display
10.Liquid material	G	304SS
	H	316L
	T()	Other materials

Instructions:

LW-PM flat-embedded diaphragm pressure transmitter, measuring range: 0~0.1MPa, output signal 4-20mA, 24V power supply, temperature range is 0... 80°C, accuracy level 0.5%, process connection G1/2B, sealing material is fluoro rubber, electrical connection is Hersman joint, no digital display, liquid material 304SS.

Product Certification

Compliance and approval; Rodewieg pressure gauges meet key standards and certifications for process measurement technology; Thus guaranteeing the highest reliability in such Settings;